



25th International Conference on Knowledge-Based and Intelligent Information & Engineering Systems

CaregiverMatcher: graph neural networks for connecting caregivers of rare disease patients

Filippo Guerranti^{a,**}, Mirco Mannino^{a,*}, Federica Baccini^{d,e,**}, Pietro Bongini^{a,b,**}, Niccolò Pancino^{a,b,**}, Anna Visibelli^{a,c,**}, Sara Marziali^{a,**}

^aDepartment of Information Engineering and Mathematics, University of Siena, 53100, Siena, Italy

^bDepartment of Information Engineering, University of Florence, 50139, Florence, Italy

^cDepartment of Biotechnology, Chemistry and Pharmacy, University of Siena, 53100, Siena, Italy

^dDepartment of Computer Science, University of Pisa, 56124 Pisa, Italy

^eInstitute for Informatics and Telematics, CNR, 56124 Pisa, Italy

Abstract

Rare diseases affect a growing number of individuals. One key problem for patients and their caregivers is the difficulty in reaching experts and associations competent on a particular disease. As a consequence, caregivers, often family members of the patient, learn much about the disease from their own experience. CaregiverMatcher is a proof of concept providing a smart solution to build a network of caregivers, linked by a matching mechanism based on graph neural networks. The caregivers and their experience with rare diseases are described by node features. Associations and care centers are invited to share their knowledge on the platform.

© 2021 The Authors. Published by Elsevier B.V.

This is an open access article under the CC BY-NC-ND license (<https://creativecommons.org/licenses/by-nc-nd/4.0>)

Peer-review under responsibility of the scientific committee of KES International.

Keywords: Cross-platform application; Caregivers; Rare diseases; Graph Neural Networks; Deep Learning.

1. Introduction

Any disorder which has a low prevalence in the target population, typically chronic and potentially life-threatening, is known as *rare disease*. In the United States, a disease is defined as *rare* when it affects less than 200,000 people in the US population. This definition was introduced in the Orphan Drug Act of 1983 with the aim of regulating the production of drugs for the treatment of such diseases. In the European Union a rare disease is defined as a disorder “with an incidence of less than 1 per 2000 people”. This was first established in the EU legislation in Regulation (EC) 141/2000 of 16 December 1999.

* Corresponding author

** Equal contributions

E-mail address: mirco.mannino@student.unisi.it

According to Eurordis [1], the estimated number of rare diseases is higher than 6,000 and, depending on the local definitions of *rarity*, the prevalence of people suffering from them varies between 3.5% and 5.9%. This results in 263–446 millions of affected people worldwide [2]. Therefore, although rare disorders have a relatively low prevalence, the number of patients is still very large.

An important role in the support of people affected by rare diseases is that of the *caregiver*. Caregivers provide daily assistance to people with impairments caused by ageing, chronic diseases, infirmities, etc. They can be either members of the patient’s family, or people hired for providing help. An ISTAT report of 2015 [3] states that, in the European Union, 15 out of 100 people provide assistance to individuals with impairments at least once a week. Regarding care for family members, this number slightly decreases to 13. This indicates that the role of the caregiver is mostly occupied by family members, who rarely have got an adequate education on how to deal with people affected by some impairments. In addition, the constant attention to the patient’s needs, and the social isolation that the role of being caregivers entails are at the basis of the obstacles they have to deal with in the daily assistance [4]. This aspect becomes even more relevant when the assisted patient is affected by a rare disease. The diagnosis is often a slow and difficult process [5] which can lead to sudden changes in the life of a patient. Consequently, it is often challenging for a caregiver, be it a family member or not, to give immediately the appropriate support to the patient.

A further obstacle is represented by the fact that rare diseases dedicated associations are generally dispersed around the world. This makes it difficult for caregivers and their patients to communicate with specialized centers, resulting in the lack of psychological and practical support. In order to cope with the issues of isolation and poor communication with healthcare professionals, a network of caregivers is extremely valuable [6].

In this work, a proposal for the design of a cross–platform application in support of the caregiver’s experience is presented. The proposal is called *CaregiverMatcher*, and its aim would be to create a network of caregivers assisting people affected by rare diseases. Technically, *CaregiverMatcher* would exploit graph neural networks (GNNs [7]) to perform a matching (an association) between caregivers, based on information about the assisted patients. Consequently, *CaregiverMatcher* would give the caregiver the opportunity to establish a direct contact with other caregivers that face similar issues in daily assistance. Moreover, *CaregiverMatcher* would make some informative sections available, which would be dedicated to improve the knowledge about rare diseases. These sections would be curated by doctors and associations joining the platform, and they would also include contacts to medical centers and associations. In summary, besides offering the opportunity of a direct contact between caregivers to promote the sharing of experiences, *CaregiverMatcher* attempts to facilitate the exchange of information between associations, doctors and caregivers in the field of rare diseases.

The paper is organized as follows: in Section 2, some related works are presented. Section 3 explains the architectural structure of *CaregiverMatcher*. Section 4 highlights the strengths and limitations of the proposed application. Finally, Section 5 presents the conclusions of the paper.

2. Related works

Several technologies have been proposed with the aim of improving the health and well-being of caregivers, by enabling them to communicate with other caregivers [8, 9, 10]. These approaches can reduce difficulties related with the access to health care providers and resources to give an appropriate support to the assisted patient [11]. Other applications focus instead on the creation of a “health team” community, through which caregivers and patients can request information and receive feedback [12]. Finally, other support technologies provide an emergency channel through which the patient can immediately be put in contact with the caregiver [13].

However, to the best of our knowledge, existing applications do not exploit Machine Learning techniques as a mean of facilitating communications between caregivers, associations and doctors. The proposal represents an innovation in this direction, because *CaregiverMatcher* would select groups of caregivers facing similar daily issues by exploiting graph neural networks (GNNs).

GNNs, first introduced in [7] and [14], are deep neural networks designed to process graphs, which have been proven to be universal approximators on graph-structured inputs under certain conditions [15]. This family of models includes several types of architectures, that differ for structure and performed tasks (for an exhaustive taxonomy of existing GNN models see [16] and [17]). The first models to be introduced [7, 14] exploit recurrent neural networks to learn a node’s representation in a graph. Later, convolutional GNNs (GCNs) were introduced [18, 19, 20, 21]. In

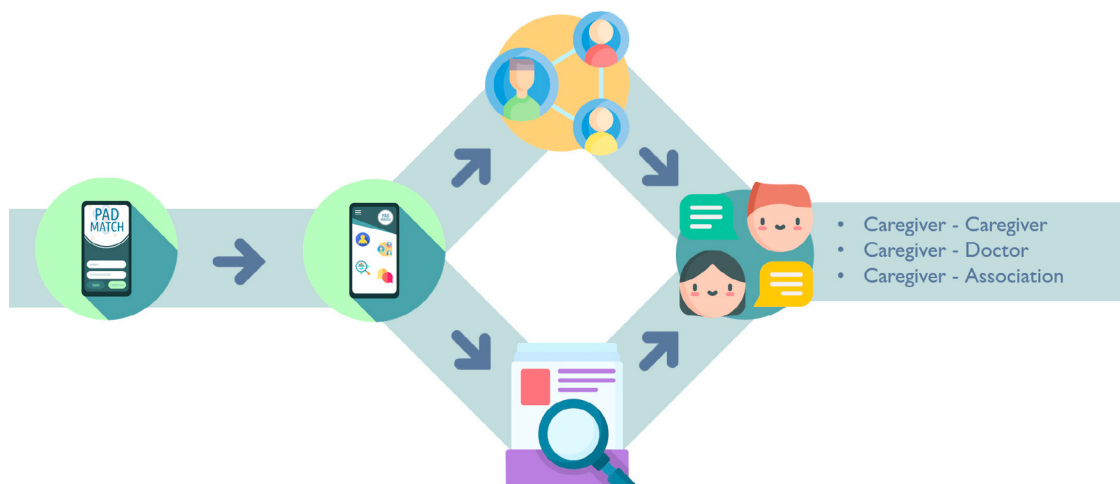

Fig. 1. General architecture of CaregiverMatcher mobile app. From the left: to access the platform, caregivers log in with username and password. Four sections are available in the home page: *Profile*, to manage personal and patient data; *Chat*, where all messages and chat conversations are stored; *Get Informed* to retrieve rare diseases information as well as associations or doctors contacts; *Match* to start the matching process. As a result, caregivers can then connect with patient associations, specialized clinicians and other caregivers.

order to learn node representations, GCNs exploit convolutional operations to aggregate the information contained in a node's neighbourhood. Moreover, the type of convolution applied to the graph has led to the definition of many different architectures, e.g. Graph Isomorphism Networks [22].

3. Materials and Methods

CaregiverMatcher main purpose is to allow caregivers to share their experience with other people, and to spread knowledge gained in the course of their assistance to patients affected by a rare disease. CaregiverMatcher can be described as a free and easy-to-use multi-platform network application, where the user can both provide and request psychological or technical support, which comes in the form of a simple chat conversation with other caregivers, patient associations and specialized doctors. This could lead to benefits in many aspects of daily life, including, for example, psychological health. In addition, more expert caregivers can spread their experience, in order to make "newcomers" benefit of the advises which have been shared on the platform.

Finally, the feeling of abandonment a caregiver can experience [23], may be mitigated by the possibility offered by CaregiverMatcher to promote the communication with associations and doctors.

3.1. Proposed architecture

During the registration on the platform, the caregiver creates a personal profile and provides some information about the patient. Information may include personal data such as age, gender, height and weight, blood group, as well as health condition, symptoms and characteristics of the specific disease affecting the patient. For example, information regarding organs involved in the disease, condition of reduced mobility, blindness, difficulties in breathing and communicating may be included. It is worth noting that these data are anonymous and intentionally generic, in order to protect the patients identity. Personal information cannot be accessed by other users: patients data are exclusively used in the matching process by the machine learning model.

Moreover, patients and caregivers data can be updated in the dedicated *Profile* section, in order to keep track of the course of the disease, as well as of the experience of the caregiver. Multiple patient records are available in the profile section to include caregivers providing assistance to more than one patient at the same time. If for some reason a new

patient replaces one of those already present in the caregiver's profile, the experience gained with the previous one is still used by CaregiverMatcher as useful information for the matching process.

In addition to the modifiable *Profile* section, CaregiverMatcher makes other three sections accessible to the user:

- *Connecting* section, where the user can discover the usernames of the matched caregivers. The association is performed by using the Deep Learning techniques described in Section 3.2, by exploiting information on similar assisted patients and similar life condition of the caregivers.
- *Chat* section, where the caregiver can communicate in real time with other people after the matching process and where all chat sessions are stored.
- *Get Informed* section, a specific area where doctors and associations provide easily understandable documentation about several rare diseases and useful links to external websites. Moreover, direct links to associations and/or doctors are available, so as to offer other communication channels to the user.

3.2. Deep learning-based matching process

The core of CaregiverMatcher is its ability to connect caregivers by means of deep learning techniques. From a practical point of view, the application checks the compatibility between caregivers based on both patient personal information and health condition. In particular, a graph neural network is exploited by the application to perform a matching between caregivers living in similar conditions. The input to the model is constituted by a vector of information regarding both the caregiver and the assisted patient health conditions. As several information could be collected to describe a caregiver in the network, it could happen that the input to the machine learning model is high dimensional. Therefore, in order to facilitate the data processing, some specific architectures, such as autoencoders, could be used to obtain a compressed representation of the input data.

The mathematical structure CaregiverMatcher is built on is constituted by graphs.

A graph is a common data structure composed of two basic elements: a finite set of nodes (vertices) and a set of arcs (edges) connecting them. In this context, nodes represent entities such as patients, while edges stand for relationships between entities, such as being affected by the same disease. Every node is then associated to a label which includes a compressed representation of patient personal information as well as health condition or symptoms and characteristics of the corresponding disease.

In order to add the caregiver information as well, another type of node, labeled with caregiver personal data, is included in the graph and connected to the patient nodes through an assistive-type relational edge. As a consequence, a heterogeneous graph is obtained. This kind of graph has been commonly used to abstract and model complex systems, in which entities of different types interact. The resulting graph is then composed of two types of nodes and edges: the former represent both patient and caregiver and the latter represents both patient-patient and caregiver-patient relationships.

Neural Networks and Deep Learning have been shown to be efficient in processing graph structured data, both in the homogeneous [16] and heterogeneous [24] domains. In particular, CaregiverMatcher matching function is based on graph neural networks (GNNs), a special class of deep learning models capable of correctly processing data in the graph domain [7], leveraging on node features and on relationships between nodes. GNNs can also include heterogeneous structural information, i.e. different types of nodes and edges, and heterogeneous features associated with each node type.

The GNN model exploited in the present application is asked to predict whether an edge exists between each pair of caregiver nodes. The predicted presence or absence of an edge represents the existence of a caregiver-caregiver relationship, and it is weighted according to a real-valued similarity score describing how compatible their profiles are: the higher the score, the higher the compatibility between the connected users.

Eventually, once the matching process has been completed, the user is returned a list of similar caregivers, filtered as needed by setting some parameters in a dedicated section: by default, the first five compatible caregivers are shown, in decreasing order with respect to the similarity score.

3.3. Graph neural network model

Graph neural networks (GNNs) are deep neural network models capable of processing graph-structured data [7]. The model input is defined as a graph $G = (V, E)$, where V is the set of nodes, $E \subseteq V \times V$ is the set of edges, and every node $v_i \in V$ is labeled with a feature vector l_i . The neighborhood of a node is defined as a function $Ne(v_i) = \{v_j : (v_j, v_i) \in E\}$ assigning a set of neighbors $Ne(v_i)$ to each node $v_i \in V$. A GNN implements two functions: a state updating function $f()$ that allows the network to define and update a state s_i for each node v_i , and an output function $g()$ that calculates the output based on the node states. Depending on the problem at hand, the output function can be defined on a set of nodes $V_{out} \subseteq V$ (see Figure 2), a set of edges $E_{out} \subseteq E$, or the whole graph.

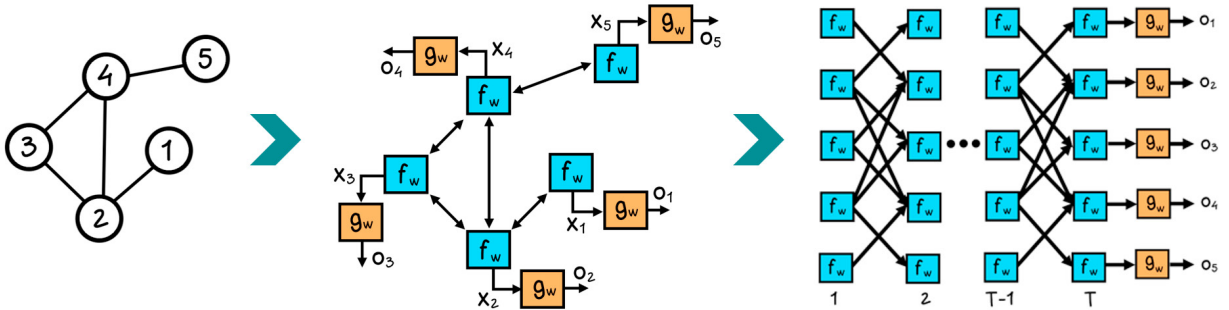

Fig. 2. Graph neural network model for general node-focused application. GNNs create an encoding network, an architecture which replicates the input graph structure by using two MLPs as building blocks. An MLP implements a state transition function f on each node; the other one implements an output function g on each node or edge (or on a subset of them). The network unfolds itself in time and space, respectively, by replicating the MLP units on each node of the input graph, and by iterating the state computations until a stable point or a maximum number of iterations is reached. In the resulting feedforward network, called *unfolding network*, each level corresponds to a time instant, and contains a copy of all the elements of the encoding network, which determines connections between the various layers.

Since the objective is to match a new (caregiver) node with the most similar (caregivers) nodes in the network, by calculating a matching score, the new node is connected to all the existing caregiver nodes. Then, an edge regression task is assigned to the GNN, where E_{out} will correspond to the subset of edges connected to the new node. After the scores have been predicted, all the edges connecting the new node to the rest of the graph, but the top-5 matching nodes, will be erased from the graph. The state updating function is defined in Eq. (1), while the edge-based output function is defined in Eq. (2)

$$s_i^k = f(s_i^{k-1}, \phi(\{s_j^{k-1} : j \in Ne(v_i)\})) \tag{1}$$

$$y_{i,j} = g(s_i^m, s_j^m) \tag{2}$$

In particular, after initializing the state of each node with its feature vector $s_i^0 = l_i$, the state calculation is iterated m times (with m being set as a hyperparameter). The state at each $1 \leq k \leq m$ iteration is calculated as in Eq. (1), based on the node state, and on the states of its neighbours at iteration $k - 1$, which are grouped by an aggregation function ϕ (sum, average, or another custom aggregation method). Therefore, nodes exchange information by sending their state vectors through the outgoing edges, and by receiving the states of their neighbours through the incoming edges. This process is called *message passing*, and allows to exploit the relationships (edges) between the nodes without breaking the graph structure. This represents an advantage in the use of graph neural networks with respect to other methods (e.g. random walks) which encode the graph into a vector before processing the graph information, often leading to a loss of structural information. Each function is implemented with a Multi-Layer Perceptron (MLP) module [25]. The state network is replicated on each node of the input graph. The output network is placed on the entities (nodes or edges) for which an output is required, depending on the type of problem. In the case of CaregiverMatcher, the output network is located on each edge linking two caregivers. Finally, all the replicas of the same MLP share their parameters [26].

3.4. Autoencoders

As many different rare diseases and patient health conditions exist, the input features of the nodes labels may be represented in a high-dimensional space. This may result in high computational costs if caregivers and patients are described by large vectors, since the model tends to work on all the available data.

In order to facilitate data processing, compressed representations of the nodes features can be obtained by using appropriate techniques. In particular, autoencoders are unsupervised machine learning models which are often used to learn compact representations of high-dimensional vectors [27, 28]. They're usually designed as feedforward neural networks composed of two sub-units: an encoder and a decoder. The former has the role of compressing the input data, while the latter learns to reconstruct the original input starting from the compressed version provided by the encoder. The last layer of the encoder could be thought of as a bottleneck which forces a compressed representation of the original input. This allows to use the encoder as a data preprocessing tool to perform feature dimensionality reduction on raw data. This is obtained, in practice, by first training the autoencoder, and then by exploiting the hidden layer output to train the machine learning model. In particular, the dimensionality of nodes features can be reduced with an autoencoder, and the resulting representation used as node labels in the GNN learning procedure.

It is worth noting that this is a special kind of unsupervised task, called self-supervised, since there is no need for a supervisor to give the correct answer to the network, as its target is the input itself.

4. Discussion: strengths and limitations

CaregiverMatcher is a cross-platform application designed to facilitate the communication between caregivers, by offering them the possibility to interact with specialists and rare disease associations. The interaction with other caregivers, with doctors and with associations are thought, in particular, for caregivers assisting patients affected by rare diseases.

Firstly, CaregiverMatcher has an intuitive and easy-to-use interface. Caregivers only have to register to the application and to select the desired page (*Chat, Get Informed, ...*). A GNN model will automatically look for a correspondence between a caregiver and other users with similar needs, based on the features of the assisted patients.

Secondly, the language used in CaregiverMatcher is easy to comprehend. This assumes a particular importance as caregivers can have different levels of education. A further advantage brought by CaregiverMatcher is the low cost of its usage, design, and implementation. Indeed, the user only needs to have a mobile phone or a PC to have access to the application. Moreover, the GNN exploited by CaregiverMatcher would perform the matching operation with a high level of accuracy in a reasonable computational time. Nevertheless, it has to be pointed out that a high level of efficiency of the application can be reached only after a variable (yet not quantifiable) amount of time. Actually, the GNN model will require a consistent amount of data (a consistent number of registered users) to efficiently perform a matching between the nodes of the network (patients and caregivers). However, even if an accurate matching is not immediately available to the user, the simplified informative pages on rare diseases, and the related useful links to web pages on related topics could be exploited as soon as CaregiverMatcher is launched.

Another crucial point in the development of CaregiverMatcher is that it is thought not only for supportive care, but also for sharing knowledge and experiences among caregivers. In the past, there have been attempts to improve support to caregivers (see, for example, the COPE project [29, 30]). However, these attempts were mostly focused on giving supportive care, rather than on offering a concrete possibility of sharing experiences. In contrast, CaregiverMatcher is designed to offer a multidisciplinary psychological support to caregivers. The opportunity to virtually talk with other caregivers with similar experiences results in an occasion for giving/receiving help in daily problems. It is well established that support groups for caregivers lead to improvements in psychological well-being, caregiver burden, and social consequences [31]. Indeed a lot of caregivers have limited access to information and resources that exist in their communities, and often report feelings of isolation and inadequate social support [32]. The chat page of CaregiverMatcher gives the caregiver a real-time opportunity to express private feelings, by establishing a connection with caregivers assisting patients with similar diseases.

In particular, the writing process immediately after an emotionally charged event has already been described as therapeutic [33]. Interventions comprising provision of information, psycho-educational and supportive interventions offered by professionals and associations have the aim of improving the well-being of the caregiver [34]. Associa-

tions are responsible for producing reliable educational material, information on diseases, available treatments and the location of knowledgeable clinicians. Finally, CaregiverMatcher provides a solution for practical needs as well, especially during the spread of the COVID-19 pandemic. The system puts the caregivers in contact with medical specialists, when possible, avoiding unnecessary visits to care centres and reducing the risks and difficulties connected to traveling, especially in the case of patients suffering from rare diseases [35].

5. Conclusions

The purpose of this paper is to make a project proposal for a machine learning based application which supports caregivers in daily life. The proposed solution, CaregiverMatcher, consists in a free and easy-to-use multi-platform application which facilitates communication between caregivers, patients associations and specialists. A direct communication channel between caregivers is realized by means of a graph neural network, which performs a matching between similar caregivers based on information regarding both the assisted patient and the living conditions of the caregiver. The use of graph neural networks is the most innovative aspect of this proposal, as GNNs allow to efficiently process input data in the graph domain by exploiting both features describing the graph nodes (in this case, caregivers and patients), and the edges (relations) between them. Moreover, as the potentially high dimensionality of the input features describing the nodes of the graph may affect the performance of the GNN, an option to enrich the application would be to use an autoencoder to obtain a compressed representation of the input data. A further advantage in this proposal is that CaregiverMatcher would perform the matching with a heterogeneous graph as input. This allows to take into account relevant information about the assisted patient, as well as problems encountered by the caregiver in the daily assistance.

Overall, CaregiverMatcher aims at improving the caregivers knowledge not only by providing direct contact with other caregivers, but also by offering a section of easily understandable information material on rare diseases, provided by associations, doctors and health professionals, with useful links to get in touch with doctors or associations, as well as to external websites or to additional material.

In conclusion, CaregiverMatcher may result in benefits in many aspects of caregivers life, including mental health, by providing psychological and practical support, along with the possibility to easily access reliable educational material offered by professionals and associations.

Acknowledgements

We want to thank Professor Monica Bianchini for supporting us in this work. This project and all the ideas described so far are based on the *PADMatch* finalist project proposed by the authors of this paper for the Italian *Rare Disease Hackathon 2020 (digital edition)*, an online event held by *Forum Sistema Salute* with the aim of promoting technological innovation applied to rare diseases, so as to facilitate the lives of patients suffering from them. In particular, *PADMatch* offered a possible solution for the challenge *The caregiver: which needs? Competencies and supporting technologies*, entering the final round of the event.

References

- [1] Eurordis. About rare diseases. URL <https://www.eurordis.org/about-rare-diseases>.
- [2] Stéphanie Nguengang Wakap, Deborah M Lambert, Annie Olry, Charlotte Rodwell, Charlotte Gueydan, Valérie Lanneau, Daniel Murphy, Yann Le Cam, and Ana Rath. Estimating cumulative point prevalence of rare diseases: analysis of the orphanet database. *European Journal of Human Genetics*, 28(2):165–173, 2020. URL <https://doi.org/10.1038/s41431-019-0508-0>.
- [3] ISTAT. Condizioni di salute e ricorso ai servizi sanitari in Italia e nell'Unione europea - Indagine Ehis 2015, 2017. URL <https://www.istat.it/it/archivio/204655>.
- [4] Maryam Navaie-Waliser, Penny H. Feldman, David A. Gould, Carol Levine, Alexis N. Kuerbis, and Karen Donelan. When the Caregiver Needs Care: The Plight of Vulnerable Caregivers. *American Journal of Public Health*, 92(3):409–413, mar 2002. ISSN 0090-0036, 1541-0048. URL <https://doi.org/10.2105/AJPH.92.3.409>.
- [5] J Thevenon, Y Duffourd, A Masurel-Paulet, M Lefebvre, F Feillet, S El Chehadeh-Djebbar, J St-Onge, A Steinmetz, F Huet, M Chouchane, V Darmency-Stamboul, P Callier, C Thauvin-Robinet, L Faivre, and J.B. Rivire. Diagnostic odyssey in severe neurodevelopmental disorders: toward clinical whole-exome sequencing as a first-line diagnostic test. *Clinical Genetics*, 89(6), 2016. ISSN 00099163. doi: 10.1111/cge.12732. URL <https://doi.org/10.1111/cge.12732>.

- [6] Eylin Palamaro Munsell, Ryan P. Kilmer, James R. Cook, and Charlie L. Reeve. The effects of caregiver social connections on caregiver, child, and family wellbeing. *American Journal of Orthopsychiatry*, 82(1):137–145, 2012. ISSN 1939-0025, 0002-9432. URL <https://doi.org/10.1111/j.1939-0025.2011.01129.x>.
- [7] F. Scarselli, M. Gori, A. C. Tsoi, M. Hagenbuchner, and G. Monfardini. The graph neural network model. *IEEE Transactions on Neural Networks*, 20(1):61–80, 2009. URL <https://doi.org/10.1109/TNN.2008.2005605>.
- [8] Ianacare, support family caregivers and the people in their lives who want to help. URL <https://www.ianacare.com/how-it-works>.
- [9] CaringBridge, keep your family and friends updated during a difficult time., . URL <https://www.caringbridge.org/how-it-works/>.
- [10] Caring Village, free help for caregivers, . URL <https://www.caringvillage.com/>.
- [11] Med Guide : Medication Optimization supported via Telehealth. URL <https://illuminate.health/home-2/med-guide/>.
- [12] Matheus Costa Stutzel, Michel Pedro Filippo, Alexandre Sztajnberg, Rosa Maria E.M. da Costa, André da Silva Brites, Luciana Branco da Motta, and Célia Pereira Caldas. Multi-part quality evaluation of a customized mobile application for monitoring elderly patients with functional loss and helping caregivers. *BMC Medical Informatics and Decision Making*, 19(1):140, 2019. ISSN 1472-6947. URL <https://doi.org/10.1186/s12911-019-0839-3>.
- [13] Fbio Ferreira, Flvio Dias, João Braz, Ricardo Santos, Roberto Nascimento, Carlos Ferreira, and Ricardo Martinho. Protege: A mobile health application for the elder-caregiver monitoring paradigm. *Procedia Technology*, 9:1361–1371, 2013. ISSN 2212-0173. URL <https://doi.org/10.1016/j.protcy.2013.12.153>.
- [14] Alessandro Sperduti and Antonina Starita. Supervised neural networks for the classification of structures. *IEEE Transactions on Neural Networks*, 8(3):714–735, 1997.
- [15] Franco Scarselli, Marco Gori, Ah Chung Tsoi, Markus Hagenbuchner, and Gabriele Monfardini. Computational capabilities of graph neural networks. *IEEE Transactions on Neural Networks*, 20(1):81–102, 2008. URL <https://doi.org/10.1109/TNN.2008.2005141>.
- [16] Z. Wu, S. Pan, F. Chen, G. Long, C. Zhang, and P. S. Yu. A comprehensive survey on graph neural networks. *IEEE Transactions on Neural Networks and Learning Systems*, 32(1):4–24, 2021. URL <https://doi.org/10.1109/TNNLS.2020.2978386>.
- [17] Peter W. Battaglia, Jessica B. Hamrick, Victor Bapst, Alvaro Sanchez-Gonzalez, Vinicius Zambaldi, Mateusz Malinowski, Andrea Tacchetti, David Raposo, Adam Santoro, Ryan Faulkner, Caglar Gulcehre, Francis Song, Andrew Ballard, Justin Gilmer, George Dahl, Ashish Vaswani, Kelsey Allen, Charles Nash, Victoria Langston, Chris Dyer, Nicolas Heess, Daan Wierstra, Pushmeet Kohli, Matt Botvinick, Oriol Vinyals, Yujia Li, and Razvan Pascanu. Relational inductive biases, deep learning, and graph networks, 2018.
- [18] Thomas N Kipf and Max Welling. Semi-supervised classification with graph convolutional networks. In *5th International Conference on Learning Representations, ICLR 2017*, 2017.
- [19] Michaël Defferrard, Xavier Bresson, and Pierre Vandergheynst. Convolutional neural networks on graphs with fast localized spectral filtering. In *Advances in neural information processing systems*, pages 3844–3852, 2016. URL <https://doi.org/10.5555/3157382.3157527>.
- [20] Joan Bruna, Wojciech Zaremba, Arthur Szlam, and Yann LeCun. Spectral networks and deep locally connected networks on graphs. In *2nd International Conference on Learning Representations, ICLR 2014*, 2014. URL <https://doi.org/10.1109/TNN.2008.2005141>.
- [21] Will Hamilton, Zhitao Ying, and Jure Leskovec. Inductive representation learning on large graphs. In *Advances in neural information processing systems*, pages 1024–1034, 2017.
- [22] Keyulu Xu, Weihua Hu, Jure Leskovec, and Stefanie Jegelka. How powerful are graph neural networks? *arXiv preprint arXiv:1810.00826*, 2018.
- [23] Paola Cardinali, Laura Migliorini, and Nadia Rania. The caregiving experiences of fathers and mothers of children with rare diseases in italy: Challenges and social support perceptions. *Frontiers in Psychology*, 10:1780, 2019. ISSN 1664-1078. URL <https://doi.org/10.3389/fpsyg.2019.01780>.
- [24] Ziniu Hu, Yuxiao Dong, Kuansan Wang, and Yizhou Sun. Heterogeneous graph transformer. In *Proceedings of The Web Conference 2020, WWW '20*, page 27042710, New York, NY, USA, 2020. Association for Computing Machinery. ISBN 9781450370233. URL <https://doi.org/10.1145/3366423.3380027>.
- [25] Alberto Rossi, Matteo Tiezzi, Giovanna Maria Dimitri, Monica Bianchini, Marco Maggini, and Franco Scarselli. Inductive–transductive learning with graph neural networks. In Trentin E. Pancioni L., Schwenker F., editor, *Artificial Neural Networks in Pattern Recognition. ANNPR 2018, Lecture Notes in Computer Science, vol 11081*, pages 201–212. Springer, Cham, 2018. URL https://doi.org/10.1007/978-3-319-99978-4_16.
- [26] Niccol Pancino, Alberto Rossi, Giorgio Ciano, Giorgia Giacomini, Simone Bonechi, Paolo Andreini, Franco Scarselli, Monica Bianchini, and Pietro Bongini. Graph neural networks for the prediction of proteinprotein interfaces. In *28th European Symposium on Artificial Neural Networks, Computational Intelligence and Machine Learning (online event)*, pages 127–132, 2020. URL <http://hdl.handle.net/11365/1117820>.
- [27] Geoffrey E Hinton and Ruslan R Salakhutdinov. Reducing the dimensionality of data with neural networks. *science*, 313(5786):504–507, 2006. URL <https://doi.org/10.1126/science.1127647>.
- [28] Laurens Van Der Maaten, Eric Postma, and Jaap Van den Herik. Dimensionality reduction: a comparative review. *J Mach Learn Res*, 10 (66-71):13, 2009.
- [29] Mike Nolan and Ian Philip. Cope: towards a comprehensive assessment of caregiver need. *British Journal of Nursing*, 8(20):1364–1372, 1999. URL <https://doi.org/10.12968/bjon.1999.8.20.1364>.
- [30] KJ McKee, I Philp, G Lamura, C Prouskas, Birgitta Öberg, Barbro Krevers, L Spazzafumo, B Bien, C Parker, MR Nolan, et al. The cope index—a first stage assessment of negative impact, positive value and quality of support of caregiving in informal carers of older people. *Aging & mental health*, 7(1):39–52, 2003. URL <https://doi.org/10.1080/1360786021000006956>.
- [31] Ling-Yu Chien, Hsin Chu, Jong-Long Guo, Yuan-Mei Liao, Lu-I Chang, Chiung-Hua Chen, and Kuei-Ru Chou. Caregiver support groups in patients with dementia: A meta-analysis. *International journal of geriatric psychiatry*, 26:1089–98, 10 2011. URL <https://doi.org/10.1002/gps.2660>.

- [32] Kenneth E. Miller, Heba Ghalayini, Maguy Arnous, Fadila Tossyeh, Alexandra Chen, Myrthe van den Broek, Gabriela V. Koppenol-Gonzalez, Joy Saade, and Mark J.D. Jordans. Strengthening parenting in conflict-affected communities: development of the caregiver support intervention. *Global Mental Health*, 7:e14, 2020. doi: 10.1017/gmh.2020.8. URL <https://doi.org/10.1017/gmh.2020.8>.
- [33] Brian Perron. Online support for caregivers of people with a mental illness. *Psychiatric Rehabilitation Journal*, 26(1):70, 2002. URL <https://doi.org/10.2975/26.2002.70.77>.
- [34] Sharon Nelis, Catherine Quinn, and Linda Clare. Information and support interventions for informal caregivers of people with dementia. *Cochrane Database of Systematic Reviews*, 2007. URL <https://doi.org/10.1002/14651858.CD006440>.
- [35] Sridhar Vaitheswaran, Monisha Lakshminarayanan, Vaishnavi Ramanujam, Subashini Sargunan, and Shreenila Venkatesan. Experiences and needs of caregivers of persons with dementia in india during the covid-19 pandemica qualitative study. *The American Journal of Geriatric Psychiatry*, 28(11):1185–1194, 2020. ISSN 1064-7481. URL <https://doi.org/10.1016/j.jagp.2020.06.026>.